

Design of Humidity Control with Automatic Drip Irrigation System Based on Fuzzy Logic Using Node-RED and MQTT on Cactus Plants

Rachma Dianty
Departement of Electrical Engineering
UIN Sunan Gunung Djati Bandung
Bandung, Indonesia
rachmadianyy@gmail.com

Edi Mulyana
Departement of Electrical Engineering
UIN Sunan Gunung Djati Bandung
Bandung, Indonesia
edim@uinsgd.ac.id

Rina Mardiaty
Departement of Electrical Engineering
UIN Sunan Gunung Djati Bandung
Bandung, Indonesia
r_mardiaty@uinsgd.ac.id

Dedi Supriadi
Faculty of Adab and Humanities
UIN Sunan Gunung Djati Bandung
Bandung, Indonesia
ded.supriadi@uinsgd.ac.id

Abstract—This paper presents the design and implementation of fuzzy logic model for control the humidity of Cactus plant which is integrated with an automatic drip irrigation system. This proposed system not only can control the humidity but also can give an information about the humidity of Cactus using the Node-RED-based MQTT protocol. This fuzzy modeling has two input variables and two output variables. The input variable was come from two sensors, namely the soil moisture sensor as a sensor for measuring soil moisture, and the DHT22 sensor as a measure of air temperature in Cactus plants. The output variables are the duration time of drip irrigation and duration time of lights on. In this research, we use a case study of 28.3°C for temperature and 60% for soil moisture as an input. The simulation shows that the output of fuzzy model are 0 seconds for the duration of the watering time and 3 minutes for the long duration of the lamp on. Furthermore, the proposed system shows the same output with the simulation. This result indicates that the fuzzy model for controlling the humidity of Cactus was successfully implemented in our system. The monitoring system in this system also gives a good performance. These results concluded that the proposed system already running well to control the humidity of Cactus plant.

Keywords— NodeMCU ESP8266, Sensor, Fuzzy Logic, MQTT, Node-RED.

I. INTRODUCTION

The development of the technology has been rapidly increase and does not follow physical boundaries and extends its roots in all directions. One of the technology that have been trending today is Internet of Things (IoT). IoT is a powerful tools in many aspect of sector since IoT devices has made a qualitative leap through sensor networks, analyzing data on sensor values which connected through automation platform equipment [1]. In agricultural sector, IoT plays an important role to help human in order to increase the productivity of crop by make an better system to control and monitor the condition of plant [2].

Since this pandemic condition, many people that should stay at home is looking for a new activity which can make them feel not bored to stay at home for a long time. One of the trending activity is dealing with crop a plant. Cactus is one of the plant that become favorite in this pandemic condition. Cactus (Cactaceae) is a horticultural plant in America that has 2000 species with different colors and shapes [3]. Literally, Cactus plants should live in low soil moisture and high temperatures. A good Cactus could be influenced by the soil moisture (water intensity). Cactus plants can live in highland areas with optimal temperatures of 26°C-34°C [4]. In order to produce a beautiful Cactus plants, we can developed a system that has scheduled watering, so that can reach an optimal level of soil moisture and temperature.

In IoT, The Message Queue Telemetry Transport (MQTT) protocol is one of the protocols that plays an important role in IoT communication. The MQTT protocol is lightweight and can be used as the smallest measurement and monitoring device. In its implementation, the MQTT protocol requires a broker as an intermediary between the publisher and the customer [5]. Node-Red as an automation model was developed with a sensor data acquisition system integrated with Node-Red software as a service. Node-Red implements cloud technology for data communication using MQTT.

Research on soil temperature and humidity monitoring systems in the agricultural sector has been widely used in Indonesia [6]. Fali et al. has researched a temperature and humidity monitoring system in a room based on the MQTT protocol which can show three conditions of temperature and humidity of plants [7]. In addition, there are several other studies related to MQTT communication technology that has been developed in the same case which is to developed monitoring system for plants [8][9][10]. Meanwhile, Oktavinus et al. has researched a Cactus plant monitoring system developed using Arduino Uno as the main controller to detect soil conditions on cactus plants which then will be displayed on the application interface [11].

Based on the description above, the study that combined a monitoring system with an automatic drip irrigation are

still rare. Therefore, in this study we proposed a monitoring and control system which also integrated to the automatic watering system for Cactus plant. In this system, we used NodeMCU Esp8266 as a microcontroller which will be connected to the DHT22 temperature sensor and soil moisture sensor. NodeMCU will collect data from sensors and process the data using fuzzy logic and will publish it to the MQTT broker. The fuzzy logic could be use efficiently when integrated with MQTT protocol [12].

Furthermore, fuzzy logic model is one of the methods that can be used for control several variable to obtained the output that we need. In the process of utilizing fuzzy logic, there are several things that must be considered, one of which is how to process input into output through an inference system fuzzy. Fuzzy logic can be used to determine the length of time or the speed of the motor rotates by adjusting the duty cycle for each motor [13][14] [15]. So, the fuzzy that implemented in this study is aim to have an optimal drip irrigation and run it automatically.

The rest of this paper is organized as follows. The explanation about the proposed system design is presented in Section II. The implementation and the result of this whole system are shown in Section III. Finally, in Section IV we conclude this study.

II. PROPOSED SYSTEM DESIGN

A. System Model

The grand design of our proposed system consists of three main systems, namely *publisher*, *broker* and *subscriber* as shown in Fig. 1. In this study, NodeMCU ESP8266 is used as a microcontroller which integrated with fuzzy logic control and then published it using MQTT broker to be seen in our monitoring system. The MQTT Broker that we used is Eclipse Mosquitto as an open source messaging broker. The monitoring system can be seen in the dashboard based on Node-RED platform which is easier to design and manage a data flow which can be displayed in many kind of form, such as gauges, text and graphs.

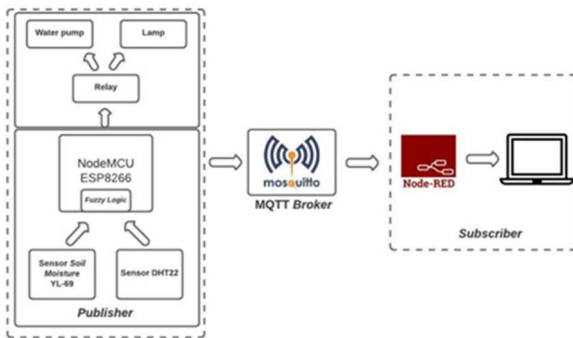

Fig. 1. Control system diagram.

B. Membership Function

Fuzzy logic modeling is designed as a high-order system with a transfer function in the form of equations. Fuzzy logic modeling is done with linguistic terms that represent the workings of human operators. Where this control is a set of linguistic control rules derived heuristically based on the state of the process. In order to have a beautiful Cactus, the optimal temperature value is 26°C–34°C, and soil moisture

is 50.00%–70.00%. So, in this fuzzy model we will control the temperature and the humidity of Cactus in a certain value. The input of this fuzzy are temperature and humidity. Table I shows the linguistic term of input, which are soil moisture and temperature. We defined the soil moisture become three levels, namely dry, normal, and wet. Meanwhile, temperature also defined in three levels, namely cold, normal, and hot.

TABLE I. LINGUISTIC TERMS INPUT

	Description	Fuzzy Set	Range (°C)
Input	Soil Moisture	Dry	[30 40 50 60]
		Normal	[50 60 70 80]
		Wet	[70 80 90 90]
	Temperature	Cold	[10 10 16 22]
		Normal	[16 22 28 34]
		Hot	[28 34 40 40]

Table II shows the linguistic term of output. The output in our system are the duration time of water pump and lights on. The level of duration time for water pump and light on are define in four levels, which are off, short, moderate, and long.

TABLE II. LINGUISTIC TERMS OUTPUT

Output	Description	Fuzzy Set	Range (second)
Pump	Off		[0 0 0 0]
	Short		[0 0 5 10]
	Moderate		[5 10 15 20]
	Long		[15 20 25 25]
	Description	Fuzzy Set	Range (minute)
Light	Off		[0 0 0 0]
	Short		[0 0 5 10]
	Moderate		[5 10 15 20]
	Long		[15 20 25 25]

After we define the linguistic terms of input and output, next step we figure out the membership function using trapezoidal curve. Figure 2 shows the membership function of temperature. The membership function equation for Figure 2 is expressed by Equation (1), (2), and (3).

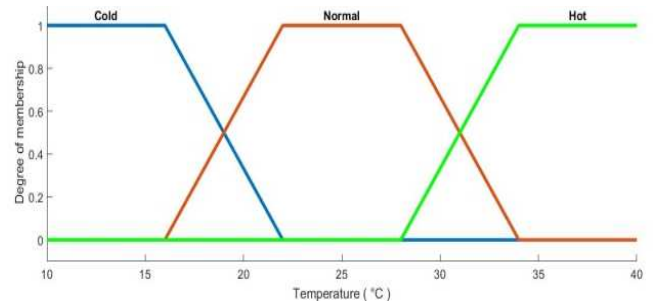

Fig. 2. Membership function of temperature.

$$\mu_{Scold}[x] = \begin{cases} 1, & x \leq 16 \\ \frac{22-x}{6}, & 16 \leq x \leq 22 \\ 0, & x \geq 22 \end{cases} \quad (1)$$

$$\mu_{Normal}[x] = \begin{cases} \frac{16-x}{-6}, & 16 \leq x \leq 22 \\ 1, & 22 \leq x \leq 28 \\ \frac{34-x}{6}, & 28 \leq x \leq 34 \\ 0, & 16 \geq x \geq 34 \end{cases} \quad (2)$$

$$\mu_{hot}[x] = \begin{cases} \frac{28-x}{-6}, & 28 \leq x \leq 34 \\ 1, & x \geq 34 \\ 0, & x \leq 28 \end{cases} \quad (3)$$

Fig. 3. shows the membership function of humidity which each level can be expressed in Equation (4), (5), and (6).

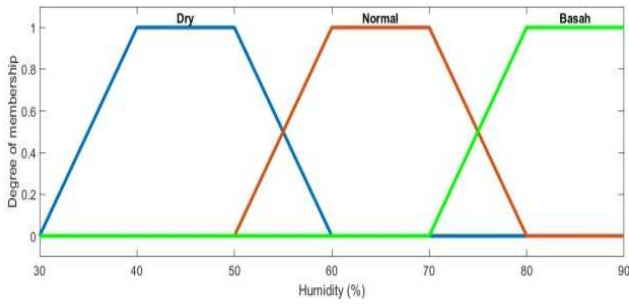

Fig. 3. Membership function of humidity.

$$\mu_{Dry} = \begin{cases} \frac{30-x}{-10}, & 30 \leq x \leq 40 \\ 1, & 40 \leq x \leq 50 \\ \frac{60-x}{10}, & 50 \leq x \leq 60 \end{cases} \quad (4)$$

$$\mu_{normal} = \begin{cases} \frac{50-x}{-10}, & 50 \leq x \leq 60 \\ 1, & 60 \leq x \leq 70 \\ \frac{60-x}{10}, & 70 \leq x \leq 80 \end{cases} \quad (5)$$

$$\mu_{wet} = \begin{cases} \frac{70-x}{-10}, & 70 \leq x \leq 80 \\ 1, & 80 \leq x \leq 90 \end{cases} \quad (6)$$

Fig. 4 and 5 are shows the membership function of water pump and light on duration. Fig. 4 and 5 has the same linguistic term with the same value also. The mathematical expression for these two membership function are expressed in Equation (7), (8), (9), (10).

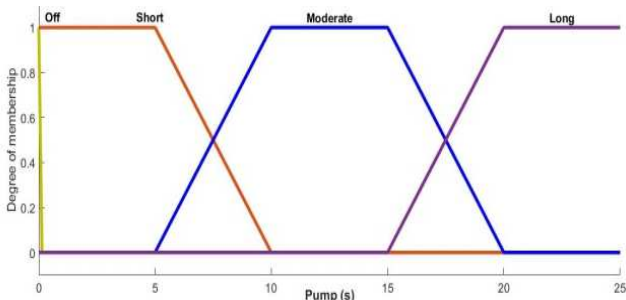

Fig. 4. Membership function of water pump duration

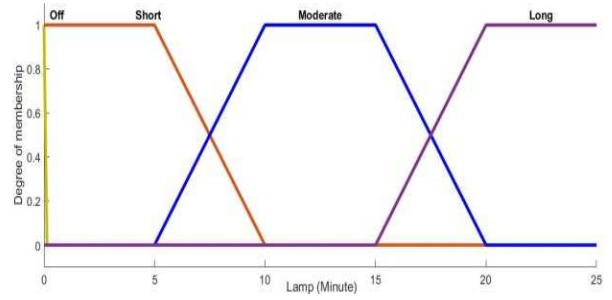

Fig. 5. Membership function of lamps on duration.

$$\mu_{off} = 0 \quad (7)$$

$$\mu_{short} = \begin{cases} \frac{5-x}{-5}, & 5 \leq x \leq 10 \\ 1, & 10 \leq x \leq 15 \\ \frac{20-x}{5}, & 15 \leq x \leq 20 \\ 0, & 5 \geq x \geq 20 \end{cases} \quad (8)$$

$$\mu_{moderate} = \begin{cases} \frac{15-x}{-5}, & 15 \leq x \leq 20 \\ 1, & 20 \leq x \leq 25 \end{cases} \quad (9)$$

$$\mu_{long} = \begin{cases} 1, & x \leq 5 \\ \frac{10-x}{5}, & 5 \leq x \leq 10 \\ 0, & x \geq 10 \end{cases} \quad (10)$$

C. Fuzzy Rules

After fuzzification process, then the next step is to make a fuzzy rule (rule base). This rules consists of a set of rules based on fuzzy logic to state a condition. The preparation of the base rule is very influential on the precision of the model, at the decision-making stage determined based on the design of the base rule. Table III shows the rules that represented if-then condition.

TABLE III. FUZZY RULES

Rules	Input		Output	
	Tempera- ture	Humidity	Water Pump	Lamp
R1	Cold	Dry	Moderate	Long
R2	Cold	Normal	Short	Long
R3	Cold	Wet	Off	Long
R4	Normal	Dry	Moderate	Short
R5	Normal	Normal	Short	Short
R6	Normal	Wet	Off	Moderate
R7	Hot	Dry	Long	Off
R8	Hot	Normal	Short	Off
R9	Hot	Wet	Off	Off

D. Hardware Design

Monitoring system requires hardware which functions to carry out instructions from the software. In general, this system is designed for monitoring and controlling the

humidity and temperature on cactus plants. In this system, there are several interconnected components. The schematic hardware design can be seen in Fig. 6. In Fig. 6, there are several components that interconnected, namely NodeMCU, DHT22 sensor, soil moisture sensor, relay, air supply, pump, and lamp.

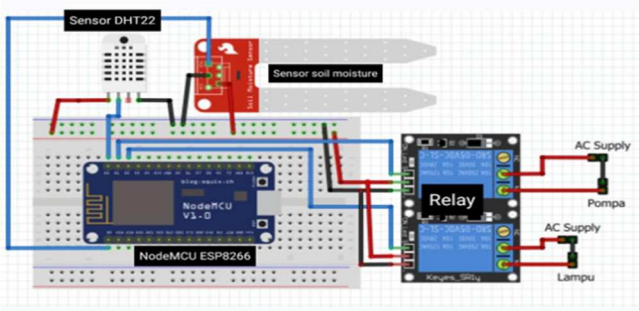

Fig. 6. Hardware schematic design.

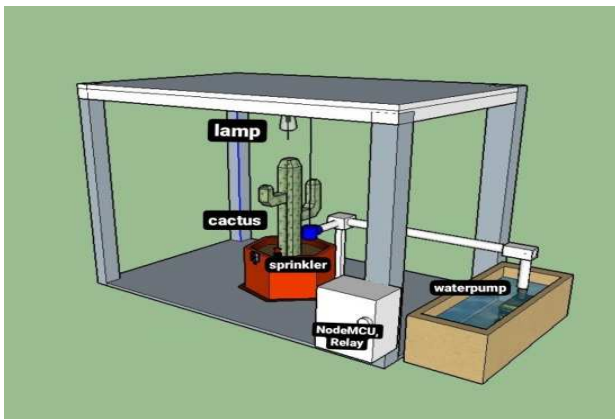

Fig. 7. Hardware implementation design.

Fig. 7. shows the illustration design of the whole integrated system that will be developed for monitoring and controlling the Cactus plant.

III. RESULT AND ANALYSIS

This experiments was carried out in bandung at 8:00 a.m, because at night the stomata condition on cactus plants is open and will be covered during the day. Fig. 8. shows the process of monitoring and controlling which the humidity and temperature are can be seen in screen monitor.



Fig. 8. The whole system.

We did the experiments to know the performance of our proposed system 15 times, as seen in Table IV. In Table IV,

we can see how the system responds to different temperature and humidity.

TABLE IV. EXPERIMENT'S RESULT

Time	Temperature (C)	Lamp (minute)	humidity (%)	Water pump (second)
0	22.6	4.8	31%	4.8
4.8	24.9	4.1	57%	3.7
8.9	27.1	3.9	62%	0
12.8	29.2	3.9	64%	0
16.7	31.7	3.8	65%	0
20.5	32.6	3.4	63%	0
23.9	33.4	2.5	61%	0
26.4	34.1	2.5	62%	2.5
28.9	33.8	1.0	67%	0
29.9	34.3	0	67%	0
29.9	34.3	0	67%	0
29.9	34.2	0	67%	0
29.9	34.1	0	67%	0
29.9	34	0	67%	0
29.9	34	0	67%	0

In order to know how well the fuzzy that have been implemented in our system, we compare the result from simulation and experiment. We used a case of temperature 28°C and humidity 69%. Based on simulation, the result from simulation show that the pump is off and the duration of light on is 3.82 minutes as shown in Fig. 9. Meanwhile, based on experiment, the result shows that the pump is off and the duration the light's on is 3 minute, as seen in Fig. 10.

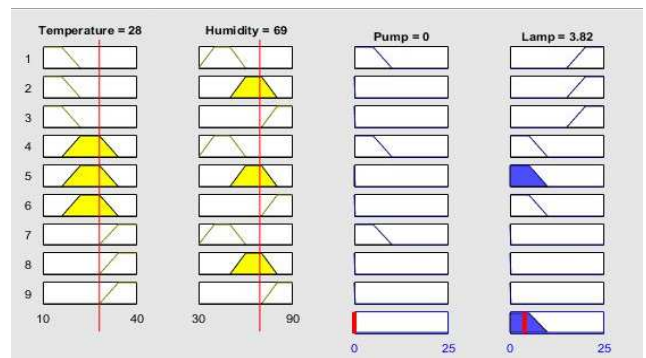

Fig. 9. Fuzzy result in simulation.

```

21:05:02.414 ->
21:05:02.414 ->
21:05:02.414 -> Entrance:
21:05:02.414 -> Suhu: 28, Kelembaban Tanah: 69 Penyir:
21:05:02.414 -> temp: 28.00
21:05:02.414 -> Humidity: 69.00
21:05:02.414 -> penyiraman: 0.00
21:05:02.414 -> lampu: 3.00
  
```

Fig. 10. Fuzzy result in our proposed system.

Based on the data obtained, it can be concluded that fuzzy logic has been well implemented in cactus plant, with that error values can be calculated by Equation 11.

$$Error = \left| \frac{x - \bar{x}}{\bar{x}} \right| \times 100\% \quad (11)$$

Where x is result from experiment, while \bar{x} is the result from simulation.

Error value duration pumps on as follows.

$$Error = \left| \frac{0.00 - 0.00}{0.00} \right| \times 100\% = 0.0\%$$

Error value duration lamps on as follows.

$$Error = \left| \frac{3,00 - 3,82}{3,86} \right| \times 100\% = 0.2\%$$

Then the data is sent using MQTT protocols to Node-RED platform, as indicated in Fig. 11. After the data sent in the form of flow on the Node-RED platform, the data result will be shown on the Node-RED dashboard as shown in Fig. 12.

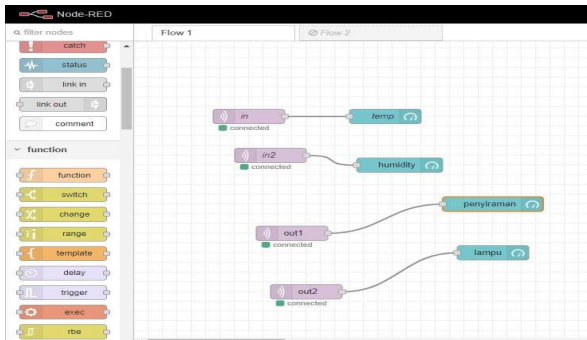

Fig. 11. Node-RED platform.

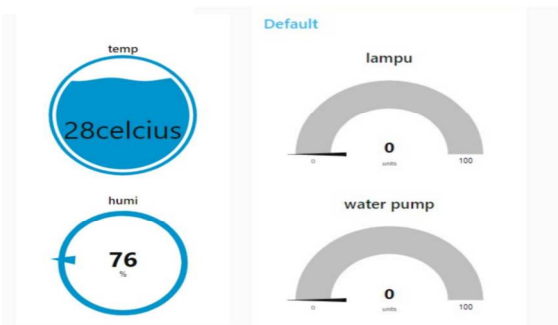

Fig. 12. Node-RED dashboard.

A. Response System

A system response or system response is a change in output behavior to a change in input signal. The response of the system in the form of this curve will be the basis for analyzing the characteristics of the system in addition to using mathematical equations/models. The shape of system response curve can be seen after obtaining the input signal. System response graph can be seen in Fig. 13 and 14.

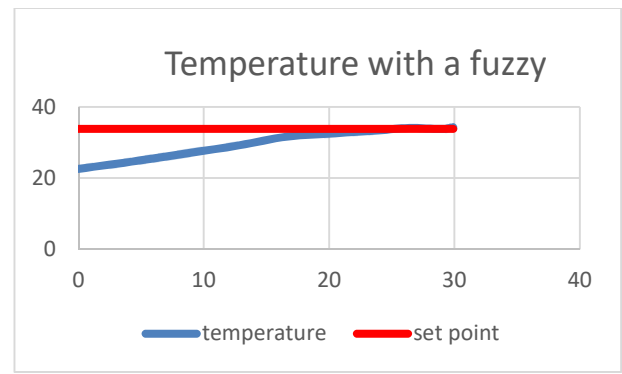

Fig. 13. Respon time of temperature.

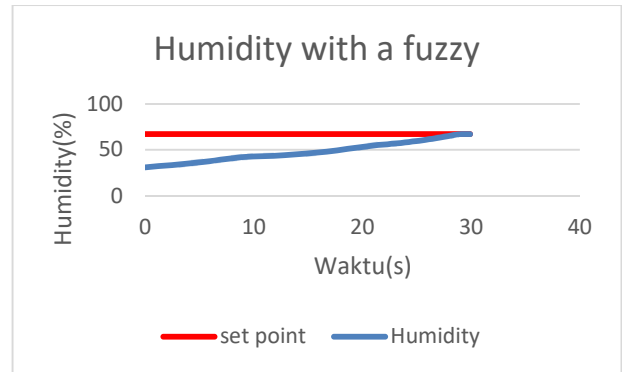

Fig. 14. Respon time of humidity.

IV. CONCLUSION

The monitoring system using *fuzzy logic* carried out by comparing the results of the test data using a case study of 28°C for temperature and 69% for soil moisture. The simulation shows that the output of fuzzy model are 0 seconds for the duration of the watering time and 3 minutes for the long duration of the lamp on. Furthermore, the proposed system shows the same output with the simulation. This result indicates that the fuzzy model for controlling the humidity of Cactus was successfully implemented in our system. The monitoring system in this system also gives a good performance. These results concluded that the proposed system already running well to control the humidity of Cactus plant.

REFERENCES

- [1] R. Akbar, R. Mardiaty, M. R. Effendi, and N. Ismail. "Fish Feeding Automation and Aquaponics Monitoring System Base on IoT." In 2020 6th International Conference on Wireless and Telematics (ICWT), pp. 1-4. IEEE, 2020.
- [2] L. Kamelia, L. Chaidir, R. Mardiaty, and A. F. Rasyid. "Design Of Smart Green House Control System For Chrysanthemum Sp. Cultivation Based On Humidity, Light And Temperature Sensors." In Asean Forum On Ict For Sustainable Rural Development And Knowledge Cross-Fertilization (ASEAN-ICT4SRD), pp. 2-6. Kuala Lumpur: Institute of Rural Advancement, 2015.
- [3] R. Djaafarer, Dazzling cacti. Jakarta: Trubus, 1987.
- [4] N. Leo, Yuliana C. Budiana, Cactus, beautiful and unique. Jakarta: Penebar swadaya, 2006.
- [5] N. A. Z. Z. Abidin, "QUIUH CAGE MONITORING SYSTEM BASED ON THE INTERNET OF THINGS ON THE NODE-RED PLATFORM USING NAIVE BAYES METHOD," J. Teknol. inf and Commune. STMIK Subang, vol. 13, no. 1, 2020.
- [6] AD. Coelho, BG. Dias, W. De Oliveira Assis, F. De Almeida Martins, and RC Pires, "Monitoring soil moisture and atmospheric sensors with internet of things (IoT) applied in precision agriculture," Proc. -

Technology 14th 2020 application to Electron. Teach. Con. TAAE 2020, 2020, doi:10.109/TAAE46915.2020.9163766.

- [7] AF. Oklilas, R. Zulfahmi, Ermatita, and AP Jaya, "Temperature Monitoring System Based on Message Queue Telemetry Transport (MQTT) Protocol," Proc. - Int. Con. Informatics, Multimedia, Cyber Inf. ICIMCIS System 2019, p. 61–66, 2019, doi:10.109/ICIMCIS48181.2019.8985356.
- [8] S. Chanthakit and C. Rattanapoka, "Mqtt-based air quality monitoring system using MCU node and node-red," Proceeding 2018 7th ICT Int. Student Project Kon. ICT-ISPC 2018, p. 3–7, 2018, doi:10.1109/ICT-ISPC.2018.8523891.
- [9] N. A-hussein and AD Salman, "IoT Monitoring System Based on MQTT Publisher/Subscriber Protocol," Iraq J. Comput. communion. Control System Ind., no. April, p. 75–83, 2020, doi:10.33103/uot.ijccce.20.3.7.
- [10] C. Rattanapoka, S. Chanthakit, A. Chimchai, and A. Sookkeaw, "An MQTT-based IoT Cloud Platform with Flow Design by Node-RED," R12C 2019 - 2019 Res. Create. innovation Congr., no. December 2019, 2019, doi:10.109/R12C48728.2019.8999942.
- [11] R. Oktavianus, NF Muchlis, JT Informatics, F. Teknik, and UH Oleo, "Design and Implementation of Android-Based Soil Moisture Monitoring System," *semanTIK*, vol. 3, no. 2, pp. 259–268, 2017.
- [12] AP. HariPriya and K. Kulothungan, "Secure-MQTT: an efficiency fuzzy logic-based approach to detect DoS attacks in MQTT protocol for internet of things," *Eurasip J. Wirel. communion. network*, vol. 2019, no. 1, 2019, doi:10.1186/s13638-019-1402-8.
- [13] Z. A. Abdul, E. Mulyana, and R. Mardiaty. "Modeling Wall Tracer Robot Motion Based on Fuzzy Logic Control." In 2020 6th International Conference on Wireless and Telematics (ICWT), pp. 1-6. IEEE, 2020.
- [14] A.E. Setiawan, R. Mardiaty and E. Mulyana. 2020, September. Design of Automatic Under Water Robot System Based on Mamdani Fuzzy Logic Controller. In 2020 6th International Conference on Wireless and Telematics (ICWT) (pp. 1-5). IEEE.
- [15] M. Abdul, R. Mardiaty, E. Mulyana, A. E. Setiawan, and A.Fathonih. "Design of Automatic Goods Carrier Robot System Based on Line Sensor and Fuzzy Logic Control Mamdani." In 2020 6th International Conference on Wireless and Telematics (ICWT), pp. 1-4. IEEE, 2020.