

Prototype Design for Object Coordinate Detection using RP LIDAR Concept

Satria Fakhri

*Department of Electrical Engineering
UIN Sunan Gunung Djati Bandung
Bandung, Indonesia
satriafakhri_id@yahoo.co.id*

Edi Mulyana

*Department of Electrical Engineering
UIN Sunan Gunung Djati Bandung
Bandung, Indonesia
edim@uinsgd.ac.id*

Rina Mardiaty

*Department of Electrical Engineering
UIN Sunan Gunung Djati Bandung
Bandung, Indonesia
r_mardiaty@uinsgd.ac.id*

Tedi Priatna

*Faculty of Tarbiyah and Education
UIN Sunan Gunung Djati Bandung
Bandung, Indonesia
tedi.priatna@uinsgd.ac.id*

Abstract—Today, the mapping and navigation systems are increasingly sophisticated, especially in detection systems. Detection system was become an important thing that could be very useful to be implemented in various fields such as searching system, exploration, military and also in the industrial sector. Detector system works using proximity sensor that can collect many environmental information by detecting objects around them. Recently, Light Detection and Ranging (LIDAR) is one of the most popular tools for detecting object. The capability of LIDAR to detecting an object is very powerful. However, since the price of LIDAR sensor is very expensive, some researchers try to solve this issue. This study proposed a prototype system for object detection based on coordinates using RP LIDAR concept which is low cost. The prototype combined the HC-SR04 ultrasonic sensor with a 360-degree continuous servo motor to build a detector system. The ultrasonic sensor is use for determined the distance and works by receiving a reflected wave from the transmitter, while the continuous servo motor is used for rotate the ultrasonic sensor, so that it can rotate 360 degrees according to the angle rotation. We do testing the performance of this prototype by using cartesian board with scenario that we set the prototype in the zero-degree position and the detection object in quadrants 1, 2, 3, 4 within a distance 5 cm - 50 cm. The result show that this prototype can detect the object coordinate with average error for x-axis is 1.178 cm and the y-axis is 1.2875 cm. This result means that the prototype was quite properly good to detect object coordinate.

Keywords—*design prototype, coordinate detection, RP LIDAR concept.*

I. INTRODUCTION

The mapping and navigation system at this time has developed rapidly. This system is implemented in the fields of search, rescue, exploration, military, hospital, and even household appliances [1]. The mapping can be useful for traversing tunnels, caves, even narrow passageways that are low on oxygen as well as heavy industrial sectors such as mining, as well as new environments whose levels of danger and safety are not known because they are not possible to be traced directly by humans. So a tool to detect the presence of objects is needed for mapping and navigation in the dangerous work area, so that humans do not need to go directly to the field which has a high accident risk.

One of the applications of the existing navigation system is using AGV (Automated Guided Vehicle) technology. AGV

can be used to send or move goods from one location to another automatically without using driver services (auto-pilot) [2]. A robot that can run automatically requires a navigation method to control the movement of the robot's speed and direction. One of the most common methods is to detect or read the obstructions around the robot. The sensors used must have a good level of accuracy and be able to reach a wide range, one of which is the RP LIDAR (Light Detection and Ranging) sensor. Data from LIDAR can be mapped and used by robots to determine localization to the environment. Then the mapping data is used by the robot for navigation and movement planning [3]. In general, LIDAR is used for mapping, however RP LIDAR can also be implemented to detect an object specifically based on the location of Cartesian coordinates.

The RP LIDAR sensor is a distance sensor that has the ability as a detector, so that the sensor can be implemented to detect an object based on the location of Cartesian coordinates. The way the sensor works is by emitting a laser beam to the object (objects) then recording the reflected wave again after colliding with the object [4]. The advantage of the RP LIDAR sensor over other proximity sensors lies in the ability of the waves to perform multiple returns, which means that the reflected wave can be recorded many times for each wave emitted [4].

However, the price of the RP LIDAR sensor is not cheap, on the official page of the sensor catalog, SLAMTEC, which is linked through its official seller, the price of the sensor varies from millions to tens of millions of rupiah [5]. Thus, research involving the use of the RP LIDAR sensor will be very costly.

Based on the problem of the enormous costs involved in using the RP LIDAR sensor, in this study the concept of the RP LIDAR sensor is used at a relatively cheap price but has the same function in detecting object coordinates, namely by maximizing the function of the ultrasonic sensor (HC-SR04) as detector combined with a 360-degree continuous servo motor as an ultrasonic sensor rotator. The detection results of the Cartesian coordinates reading will be displayed on the LCD (Liquid Crystal Display) screen.

II. RESEARCH METHODS

A. System Overview

The system to be built is an open-loop control system, which is a control system whose output does not affect the control action. Thus in this control system, the output value is not fed back to the control parameter. In this system using actuators to control the process directly, the driver here is using a 360-degree continuous servo motor that functions as an ultrasonic sensor rotator so that it can move 360 degrees according to the rotation of the angle, the sensor capture will be recorded and displayed on the LCD in the form of x coordinates and y. That way, the overall block diagram consists of three sub-block diagrams, namely the input or input block, the process block and the output or output block as shown in Figure 1.

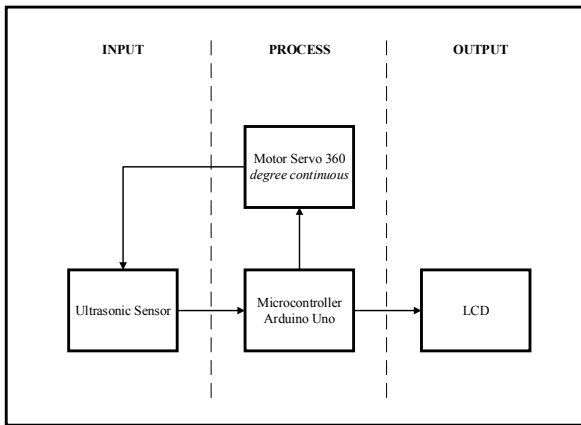

Fig. 1. Block diagram system.

The input or input block is an input or stimulus given to the control system, however, this input value does not depend on or affect the system output. In the input block, there is an ultrasonic sensor that functions as an object detector with the concept of sending and receiving ultrasonic sound waves to detect an object.

The process block consists of a controller and a plant. The controller is an equipment used to control the system as a whole by creating a program that contains source code in it to control the system. The controller used is the Arduino Uno R3 Microcontroller, to make the program itself using the Arduino IDE software, namely using the C language. Meanwhile, the plant or load is a physical system to be controlled. In this study, the load to be controlled is the drive using a 360-degree continuous servo motor that functions as a rotator / rotator so that the detector (ultrasonic sensor) can move 360 degrees according to the angle rotation.

In the output block or output is the actual response obtained from a control system. This response can be the same as the input or it may not be the same as the response to the input. The output of this research is in the form of x and y coordinates, which are displayed on a 16x2 LCD screen. The system design to be built is shown in Figure 2.

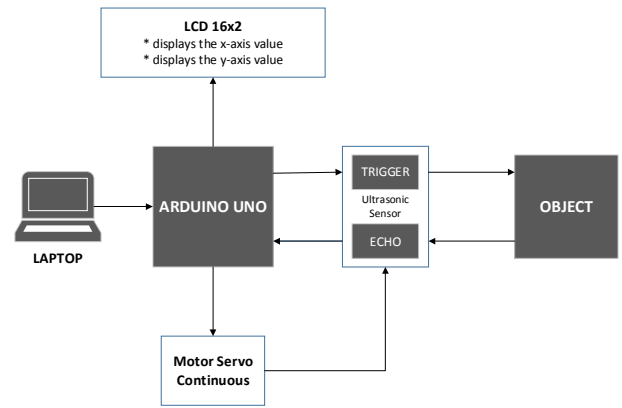

Fig. 2. Prototype's design.

In this study, the ultrasonic sensor used is the HC-SR04 sensor. This ultrasonic sensor works on the principle of sound wave reflection and is used to detect the presence of a certain object in front of it, its working frequency is at 40 KHz. The shape of the ultrasonic sensor is shown in Figure 3 [6].



Fig. 3. Ultrasonic sensor HC-SR04.

The equation for calculating the sensor distance to the object [7] that is

$$S = \frac{(t_{IN} \times V)}{2} \quad (1)$$

where,

- S : The distance of the sensor to the detected object.
- t_{IN} : Travel time of the ultrasonic waves from the transmitter to the receiver (s).
- V : Fast propagation of ultrasonic waves in the air (340 m/s).

When a trigger pulse is given for 10 microseconds on the sensor, the transmitter will start emitting eight pulses of ultrasonic waves at a frequency of 40 KHz. This 8-pulse pattern is used for an ultrasonic signal marker of this module, which allows the receiver / receiver to distinguish the transmitted pattern from the noise. ultrasonic approx. At the same time the sensor will produce an upward transition TTL output indicating the sensor starts calculating the measurement time, after the receiver receives the reflection generated by an object, the time measurement will be stopped by producing a down transition TTL output. The timing diagram of the operation of the HC-SR04 ultrasonic sensor is shown in Figure 4 [8].

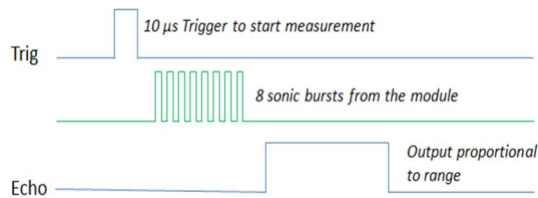

Fig. 4. Timing diagram of the operation of the ultrasonic sensor.

With the addition of a 360° continuous servo motor extension, the ultrasonic sensor can rotate to scan 360°. Then the data (output) in the form of distance (generated by ultrasonic sensors) and angle (generated by servo motors) will be processed and processed by the microcontroller which will then be converted into detection results in the form of x and y axes. The equations used to convert the data into coordinate values [3] that is

$$x_{axis} = \rho \cos \theta \quad (2)$$

$$y_{axis} = \rho \sin \theta \quad (3)$$

Where x is the cartesian coordinate value x , y is the cartesian coordinate value y and ρ is the sensor reading distance.

B. Maintaining the Integrity of the Specifications

System design determines the success of a system. In designing the hardware, it is designed to fit the needs of making a prototype of an object coordinate detector using the RP LIDAR sensor concept so that it runs well and can realize the creation of an object coordinate detector. This design involves an Arduino UNO R3 Microcontroller which functions as a data processor of ultrasonic sensor readings, controlling the movement of the servo motor and adjusting the output on the LCD. Based on the system design that has been described in the system overview, at this stage an electronic circuit design scheme is made using the Fritzing application to simplify the assembly of system realization tools. The electronic circuit schematic can be seen in Figure 5.

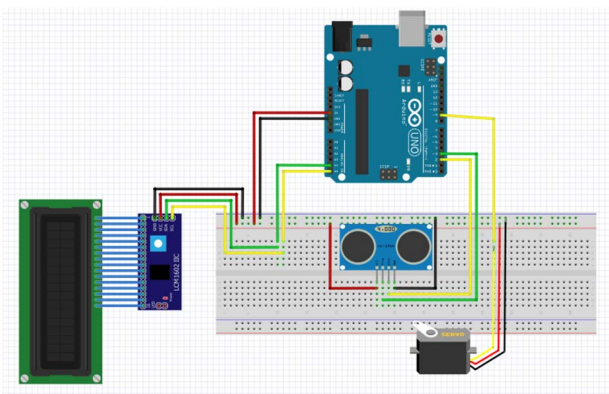

Fig. 5. Schematic electronic circuit detector prototype.

HC-SR04 ultrasonic sensor pin configuration and function:

1. The Vcc pin of the ultrasonic sensor is connected to the 5V pin of the Arduino. Serves as an ultrasonic sensor voltage,

2. The ultrasonic sensor Gnd pin is connected to the Arduino GND pin. Serves as an ultrasonic ground sensor,
3. The ultrasonic sensor trigger pin is connected to the digital pin 3 of the Arduino Uno R3. Serves to generate ultrasonic signals,
4. The ultrasonic sensor Echo pin is connected to the digital pin 2 of the Arduino Uno R3. Function to detect ultrasonic reflected signal.

The 360-degree continuous servo motor pin configuration and function:

1. The Vcc pin of the servo motor is connected to the 5V pin of the Arduino Uno R3. Serves as servo motor voltage,
2. The Gnd pin of the servo motor is connected to the GND pin of the Arduino Uno R3. Serves as servo motor ground,
3. The servo motor data pin is connected to digital pin 9 Arduino Uno R3. Serves as servo motor output.

LCD 16x2 (with I2C) pin configuration and function:

1. The Vcc I2C pin on the 16x2 LCD is connected to the 5V pin of the Arduino Uno R3. Serves as the LCD voltage along with the I2C module,
2. The Gnd I2C pin on the 16x2 LCD is connected to the Gnd pin Arduino Uno R3. Serves as a ground LCD along with the I2C module,
3. The SDA (Serial Data) I2C pin on the 16x2 LCD is connected to the A4 Arduino Uno R3 analog pin. Serves to transfer data,
4. The SCL (Serial Clock Line) pin I2C on the 16x2 LCD is connected to the analog pin A5 Arduino Uno R3. Serves to deliver the clock signal.

C. Algorithms Design

The design of the program algorithm is made with the aim of simplifying the flow of work when creating program source code using the C language in the Arduino IDE application. The algorithm explains how the system or process will be carried out by the Arduino Uno R3 microcontroller for other components, namely ultrasonic sensors, servo motors and LCDs. The microcontroller works as the brain of the device to control the circuit according to the program to be written through the C language programming code. The flow chart in Figure 6 shows how the prototype of the object coordinate detector works.

The program algorithm above states a condition, if the detected distance is more than 50 cm, the microcontroller will make the servo continue to carry out 360 degree rotational movements with scanning status. Whereas if there are objects / objects located at a distance of <50 cm, the microcontroller will stop the servo, then the data from the ultrasonic sensor and servo motor will be converted by the microcontroller into values in Cartesian coordinates, namely the x-axis and the y-axis displayed on an LCD.

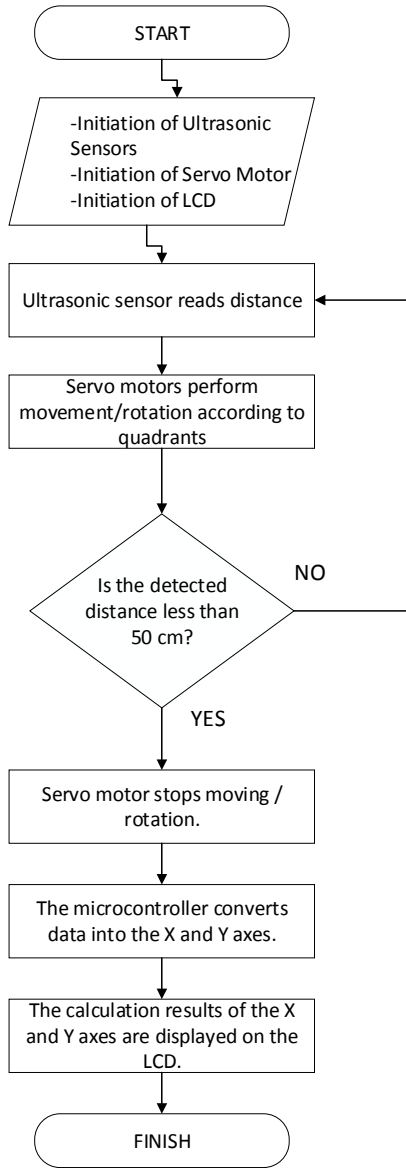

Fig. 6. Flowchart of how the detector prototype works.

III. IMPLEMENTATION AND ANALYSIS

A. Implementation

The components needed in the object coordinate detection prototype using the RP LIDAR sensor concept have 3 parts, namely the sensor part, the driving part and the output display part. The microcontroller used is the Arduino Uno R3. The hardware implementation of the prototype circuit for detecting object coordinates can be seen in Figure 7.

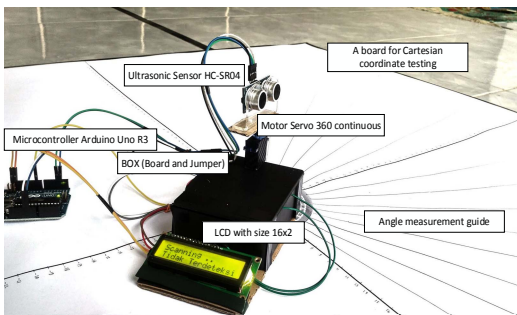

Fig. 7. Prototype of object coordinate detection tool.

B. Calibration and Testing

Ultrasonic sensor testing is done by comparing the measurement results of the ruler or meter with the ultrasonic sensor output. But before this test is carried out, the ultrasonic sensor needs to be calibrated first. The ultrasonic sensor calibration is done simply by the following equation

$$\text{Calibration} = \text{Actual Distance} - \text{Detected Distance} \quad (4)$$

The actual distance is the distance between the sensor position and the object to be detected, while the detected distance is the distance from the sensor reading to the object. In the measurement, the actual distance value = 5 cm, and the detected distance = 4 cm. So that the calibration value is obtained 1 cm, which means that the ultrasonic sensor begins to read / detect objects more than 1 cm in front of the sensor. After the sensor is calibrated, the distance response is tested. The test results for the distance response are shown in Table 1.

TABLE I. ULTRASONIC SENSOR DISTANCE RESPONSE

No.	Measurement (cm)		Error
	Ruler	Sensor	
1	5	5	0
2	10	10	0
3	15	15	0
4	20	20	0
5	25	24	1
6	30	29	1
7	35	34	1
8	40	39	1
9	45	44	1
10	50	48	2
11	55	53	2
12	60	58	2
13	65	63	2
14	70	68	2
15	75	73	2
16	80	77	3
17	85	82	3
18	90	87	3
19	95	92	3
20	100	97	3

The data obtained from the test results of the ultrasonic sensor distance response has decreased quality in reading the farther distance, it is because the farther the position of the object subjected to the wave, the greater the wave attenuation will be.

Furthermore, the reflected material is tested. This test involves several types of reflected material, in this test the object is placed at a distance of 20 cm in front of the ultrasonic sensor. Table 2 shows the test results of the ultrasonic sensor reflective material.

TABLE II. MATERIAL TESTING FOR ULTRASONIC SENSIR

No.	Type of Material	Measured Distance (cm)	Status
1	Concrete Wall	20	Detected
2	Cans (Aluminum)	20	Detected
3	Wood	20	Detected
4	Plastic Box	20	Detected
5	Plastic Bottles	20	Detected
6	Glass	20	Detected
7	Fabric	20	Detected

8	Cardboard	20	Detected
9	Paper	20	Detected
10	Tissue	20	Detected
11	Cotton	1104	ERROR
12	Tree Leaves Twigs	20	Detected

The results of this test are quite good, because almost all of these materials can be detected properly by ultrasonic sensors. Whereas the detection cotton becomes unreadable (error) because the cotton material itself is hollow and has a higher absorption reaction to sound waves with high frequencies compared to low frequencies. So that the wave cannot be reflected.

Furthermore, testing the dimensions of the sensor. This test is divided into two, namely testing the dimensions of height and width dimensions. In the height dimension test, the sensor is placed at a height of 5 cm, and the object to be detected varies from 1 cm to 5.5 cm in height, with increments every 0.5 cm. Table 3 shows the test results of the high dimensions of the ultrasonic sensor.

TABLE III. TESTING OF THE HIGH DIMENSIONS OF ULTRASONIC SENSOR

No.	Object Height (cm)	Status
1	1.0	Not Detected
2	1.5	Not Detected
3	2.0	Not Detected
4	2.5	Not Detected
5	3.0	Not Detected
6	3.5	Not Detected
7	4.0	Not Detected
8	4.5	Not Detected
9	5.0	Detected
10	5.5	Detected

The results of this test prove that the height of the object that can be detected by the sensor is the same height as the sensor is placed. While testing the position of the sensor based on the dimensions of the object is done by adjusting the position of the sensor to the object with a distance of 10 cm. The test results of the sensor width dimensions are shown in Table 4.

TABLE IV. TESTING THE POSITION OF SENSOR BASED ON THE OBJECT'S DIMENSIONS

No.	Object Width (cm)	Position to Sensor	Detected Distance (cm)
1	5.0	Middle	10
2	2.5	Middle (Trigger-Echo)	10
3	2.5	Left (Trigger)	12
4	2.5	Right (Echo)	12

Based on these data, it shows that if the position of the object is directly proportional to the sensor (trigger and echo, proportional to the object), the resulting distance is the actual distance. Meanwhile, if the object is only proportional to one of them, either trigger or echo, then the resulting distance is not the actual distance.

C. Servo Movement Testing

This servo movement test is done by comparing the results of the servo movement reading on the LCD with a 180-degree arc measuring instrument. Table 5 is the result of testing the servo motor movement.

TABLE V. TESTING OF SERVO MOTOR MOVEMENT

No.	Measurement (degree)		Status
	Protractor	Servo	
1	0	0	Corresponding.
2	10	10	Corresponding.
3	20	20	Corresponding.
4	30	30	Corresponding.
5	40	40	Corresponding.
6	50	50	Corresponding.
7	60	60	Corresponding.
8	70	70	Corresponding.
9	80	80	Corresponding.
10	90	90	Corresponding.
11	100	100	Corresponding.
12	110	110	Corresponding.
13	120	120	Corresponding.
14	130	130	Corresponding.
15	140	140	Corresponding.
16	150	150	Corresponding.
17	160	160	Corresponding.
18	170	170	Corresponding.
19	180	180	Corresponding.

Based on the test results show that the rotational movement of the servo corresponds to the degree in the arc. It can be concluded that the servo works well in rotating according to the angle rotation.

D. Testing The Entire System

Testing the whole system is an integration of an ultrasonic sensor, a 360° continuous servo motor and a display on the LCD. The test was carried out using a plywood board as a medium for measuring Cartesian coordinates. This test scenario is the distance the object can be detected is within 5 cm - 50 cm, more than that the sensor will continue to scan. The object to be detected has a height of 14.5 cm with a diameter of 1.5 cm. After getting the distance and angle values from manual measurements, to find the x-axis using Equation 2 and Equation 3 to find the y-axis. Then these results will be compared with the results of the prototype reading. The overall system test results are shown in Table 6.

TABLE VI. TESTING THE PERFORM OF SYSTEM

No.	Manual Calculation (cm)		Display LCD coordinates (cm)		Error (cm)	
	X	Y	X	Y	X	Y
1	9.09	5.25	9.80	4.90	0.71	0.35
2	4.5	7.79	5.15	8.54	0.65	0.75
3	9.57	26.31	10.39	27.10	0.82	0.79
4	6.51	36.9	5.29	37.83	1.22	0.93
5	0.00	18.00	1.26	17.22	1.26	0.78
6	-3.12	17.72	-2.63	18.65	0.49	0.93
7	-8.50	14.72	-6.64	15.65	1.86	0.93
8	-12.85	15.32	-12.59	15.54	0.26	0.22
9	-19.48	11.25	-19.05	11.03	0.43	0.22
10	-25.37	9.23	-25.77	10.90	0.40	1.67
11	-22.15	-3.90	-20.97	-1.10	1.18	2.80
12	-11.74	-4.27	-11.69	-2.43	0.05	1.84
13	-14.78	-17.61	-19.43	-14.34	4.65	3.27
14	-6.50	-11.25	-7.27	-10.71	0.77	0.54
15	-2.60	-14.77	-3.12	-14.63	0.52	0.14
16	2.95	-16.74	7.01	-14.38	4.06	2.36
17	8.20	-22.55	4.78	-22.50	3.42	0.05
18	14.93	-12.53	14.59	-15.90	0.34	3.37
19	19.48	-11.25	19.92	-11.05	0.44	0.2
20	27.25	-9.91	27.28	-6.30	0.03	3.61
Error average					1.18	1.29

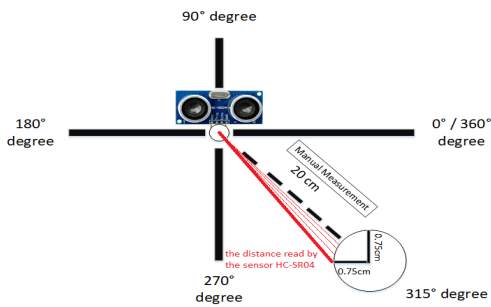

Fig. 8. Ultrasonic sensor detection of objects.

Based on the data obtained from the prototype reading, it is not too far from the measurement results and manual calculations. Even when on average, the difference between the measurement and the prototype reading is small, the mean difference for the x-axis is 1.178 and the y-axis is 1.2875. This difference can occur because there are several factors that influence it:

- First, this difference can be caused by a loss distance, as in Table 1.
- Second, these differences could be due to non-actual distance readings, as shown in Table 4.
- Third, these differences can be caused by the dimensions of the object itself. The object detected has a height of 14.5 cm and a diameter of 1.5 cm. So, the sensor has started to read or detect the object following the red line as shown in Figure 9.
- Fourth, these differences can be caused due to the movement of the servo motor that is not in accordance with the arc placed on the measuring medium. Although in Table 5 the servo performance can be said to be quite good.
- Finally, these differences can be caused by determining the data type in the source code of the program, namely using the floating-point numbers (float) data type. The float data type allows 6-7 decimal digits.

The prototype for detecting object coordinates uses the RP LIDAR sensor concept which has been designed and implemented to detect objects and can perform scanning with 360 degrees rotation within a range of 5 cm - 50 cm. Beyond this distance the HC-SR04 ultrasonic sensor and 360 degree continuous servo motor will continue to move with the status “ Scanning ... Not Detected” At the output reading, the prototype has an average difference of 1.178 for the x-axis and the y-axis of 1.2875, which is compared with manual measurements and calculations to obtain the x-axis and y-axis values.

REFERENCES

- [1] M. A. Markom et al., “Indoor Scanning and Mapping using Mobile Robot and RP Lidar,” *Int. J. Adv. Mech. Automob. Eng.*, vol. 3, no. 1, pp. 42–47, 2016.
- [2] N. T. Jayanti, A. Rusdinar, and A. S. Wibowo, “Perancangan Sistem Pengontrolan Pergerakan Automated Guided Vehicle (agv) Untuk Menarik Troli Menggunakan Sensor Lidar,” in *eProceedings of Engineering*, 2017, vol. 4, no. 2, pp. 1596–1603.
- [3] R. A. P. Ikhsan Maulana, Angga Rusdinar, “Aplikasi Lidar Untuk Pemetaan Dan Navigasi Pada Lingkungan Tertutup,” in *e-Proceeding of Engineering*, 2018, vol. 5, no. 1, pp. 1–8.
- [4] A. Emara, A. Rusdinar, and R. Nugraha, “Perancangan Algoritma Sistem Penghindar Tabrakan Pada Automatic Guided Vehicle (agv) Menggunakan Sensor Lidar,” in *eProceedings of Engineering*, 2017, vol. 4, no. 2, pp. 1402–1409.
- [5] “SLAMTEC - RobotShop (Putting robotics at your service).” [Online]. Available: <https://www.robotshop.com/en/robopeak.html>. [Accessed: 06-Jan-2020].
- [6] Fajar Rohmanu and D. Widiyanto, “Sistem Sensor Jarak Aman Pada Mobil Berbasis Mikrokontroler Arduino Atmega328,” *J. Inform. SIMANTIK*, vol. 3, no. 1, pp. 7–14, 2018.
- [7] S. F. ANINDYA and H. H. RACHMAT, “Implementasi Sistem Bel Rumah Otomatis berbasis Sensor Ultrasonik,” *ELKOMIKA J. Tek. Energi Elektr. Tek. Telekomun. Tek. Elektron.*, vol. 3, no. 1, p. 64, 2015.
- [8] S. Prayoga, A. Budianto, and A. B. Kusuma Atmaja, “Sistem Pemetaan Ruang 2D Menggunakan Lidar,” *J. Integr.*, vol. 9, no. 1, p. 73, 2017.